

TOP SLAB
NTS

DIMENSIONS OF FLUSHING / SAMPLING / TEST CORPORATION STOPS				
PURPOSE	INSTALLED LOCATION	PIPE SIZE (INCHES)	CORP. STOP SIZE (INCHES)	CORP. STOP OUTLET STYLE
SAMPLING POINT / TEST COCK	DOWNSTREAM OF METER ON TOP OF PIPE	ALL	2"	MALE NPT
FLUSHING / SAMPLING POINT	ON BOTTOM OF BYPASS LINE IN VAULT	4" - 6"	1"	MALE NPT
		8" AND GREATER	2"	

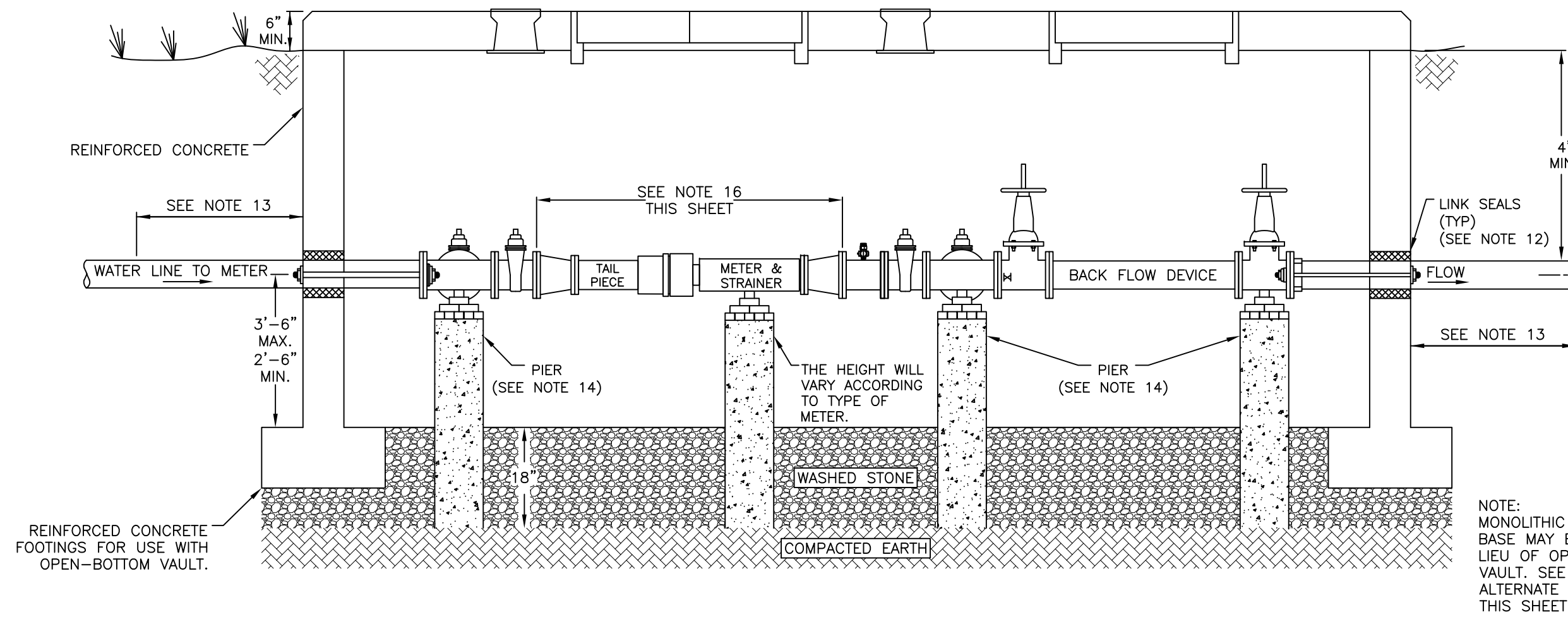

SECTION A-A
NTS

- GENERAL NOTES**
- PIT SHALL BE IN A NON-TRAFFIC AREA.
 - PIT TO BE OUTSIDE THE ROAD RIGHT-OF-WAY, COMPLETELY ON THE CUSTOMER'S PROPERTY. MAXIMUM DISTANCE FROM PROPERTY LINE IS 10'. OWNER/CONTRACTOR IS RESPONSIBLE FOR ESTABLISHING LOCATION OF RIGHT-OF-WAY.
 - PIT OWNERSHIP/MAINTENANCE IS THE RESPONSIBILITY OF THE CUSTOMER/PROPERTY OWNER.
 - IF PIT IS TO BE LOCATED IN A SLOPED AREA, IT SHALL BE DESIGNED TO MAINTAIN MINIMUM DEPTH OF COVER ON INLET PIPES. SLOPING GRADES AROUND THE PIT SHALL BE GRADED IN A MANNER TO PREVENT WATER AND DIRT FROM COVERING THE TOP OF THE PIT. LANDSCAPING AND STRUCTURES ON TOP OF PIT ARE PROHIBITED.
 - PIT SHALL NOT BE LOCATED IN AN AREA SUBJECT TO GROUND WATER RUN-OFF, STORM DRAIN COLLECTION AND DISCHARGE, OR AREAS PRONE TO CONSTANT WATER INFILTRATION. CONTRACTOR SHALL PROVIDE NON-MECHANICAL MEANS OF WATER CONTROL IF POSSIBLE AND NECESSARY.
 - ALL PITS SHALL BE LOCATED TO ALLOW SWS PERSONNEL TO ENTER AND PERFORM ANY WORK NECESSARY.
 - ALL STRUCTURAL DESIGN SHALL BE COMPLETED BY OTHERS.
 - ALL PIPE, VALVES AND FITTINGS INSIDE VAULT SHALL BE FLANGED DUCTILE IRON. ALL VALVES AND FITTINGS OUTSIDE VAULT SHALL BE MECHANICAL JOINT (MJ) DUCTILE IRON. PIPE SHALL BE DUCTILE IRON. ALL PIPING AND FITTINGS SHALL BE MANUFACTURED WITHIN THE CONTINENTAL U.S. AND SHALL CONFORM TO SWS SPECIFICATIONS.
 - STANDARD GATE VALVES ON THE BACKFLOW ASSEMBLY SHALL BE RESILIENT SEAT WEDGE OR SEAT WITH OS&Y OR NRS, OPEN LEFT. THE #1 GATE VALVE ON THE BACKFLOW ASSEMBLY SHALL HAVE A RESILIENT BALL VALVE TEST COCK. ALL GATE VALVES OUTSIDE THE VAULT SHALL BE 2" OPERATING NUT, OPEN LEFT.
 - ALL RODS SHALL BE MINIMUM 3/4" THREADED, ZINC COATED, AND HIGH TENSILE STRENGTH OF 60,000 PSI. RODS ARE TO BE STRAIGHT CONNECTED TO WALL WASHER PLATE ON EACH OUTSIDE WALL AND FIRST FLANGE INSIDE PIT. ROD CONNECTIONS INSIDE THE PIT SHALL BE INSTALLED WITH EYE BOLTS AT THE FLANGE OR OTHER ACCEPTABLE MEANS.
 - CONSTRUCTION SHALL BE COMPLETED IN ACCORDANCE WITH SWS STANDARD SPECIFICATIONS APPLICABLE AT THE TIME OF CONSTRUCTION.
 - SEAL ALL WALL PENETRATIONS WITH LINK SEAL OR APPROVED ALTERNATE.
 - NO FITTINGS SHALL BE WITHIN 2' OF VAULT.
 - SUPPORT PIERS SHALL BE INSTALLED AS SHOWN AND EXTEND TO UNDISTURBED GROUND. PIERS SHALL BE CONCRETE OR BRICK & MORTAR AND PROVIDE ADEQUATE SUPPORT. ADEQUATE CLEARANCE MUST BE MAINTAINED FOR ASSEMBLY / DISASSEMBLY OF VALVES.
 - ONLY THE FOLLOWING ITEMS ARE SUPPLIED BY SPARTANBURG WATER (IF APPLICABLE):
A) WATER METER AND STRAINER ASSEMBLY IN SIZE SPECIFIED BY SWS AND PAID FOR BY THE DEVELOPER.
B) ROMAC FLANGE ADAPTER TO FIT TAIL PIECE AND METER
 - REFER TO APPROPRIATE DIMENSION TABLE (1a, 1b or 1c) FOR METER ASSEMBLY DIMENSIONS AND WALL CLEARANCE REQUIREMENTS.
 - SERVICE WILL NOT BE TURNED ON UNTIL ALL ADMINISTRATIVE ITEMS ARE COMPLETE AND THE PIT IS COMPLETED AND ACCEPTED BY THE SWS ENGINEERING DEPARTMENT AND CROSS CONNECTION CONTROL DEPARTMENT.
 - OVERALL PIT DIMENSIONS NOT PROVIDED OR DETERMINED BY SPARTANBURG WATER. PIT SHALL BE SIZED TO MEET MINIMUM DIMENSIONS AND CLEARANCES FOR ACCESSIBILITY PROVIDED IN THESE DRAWINGS.

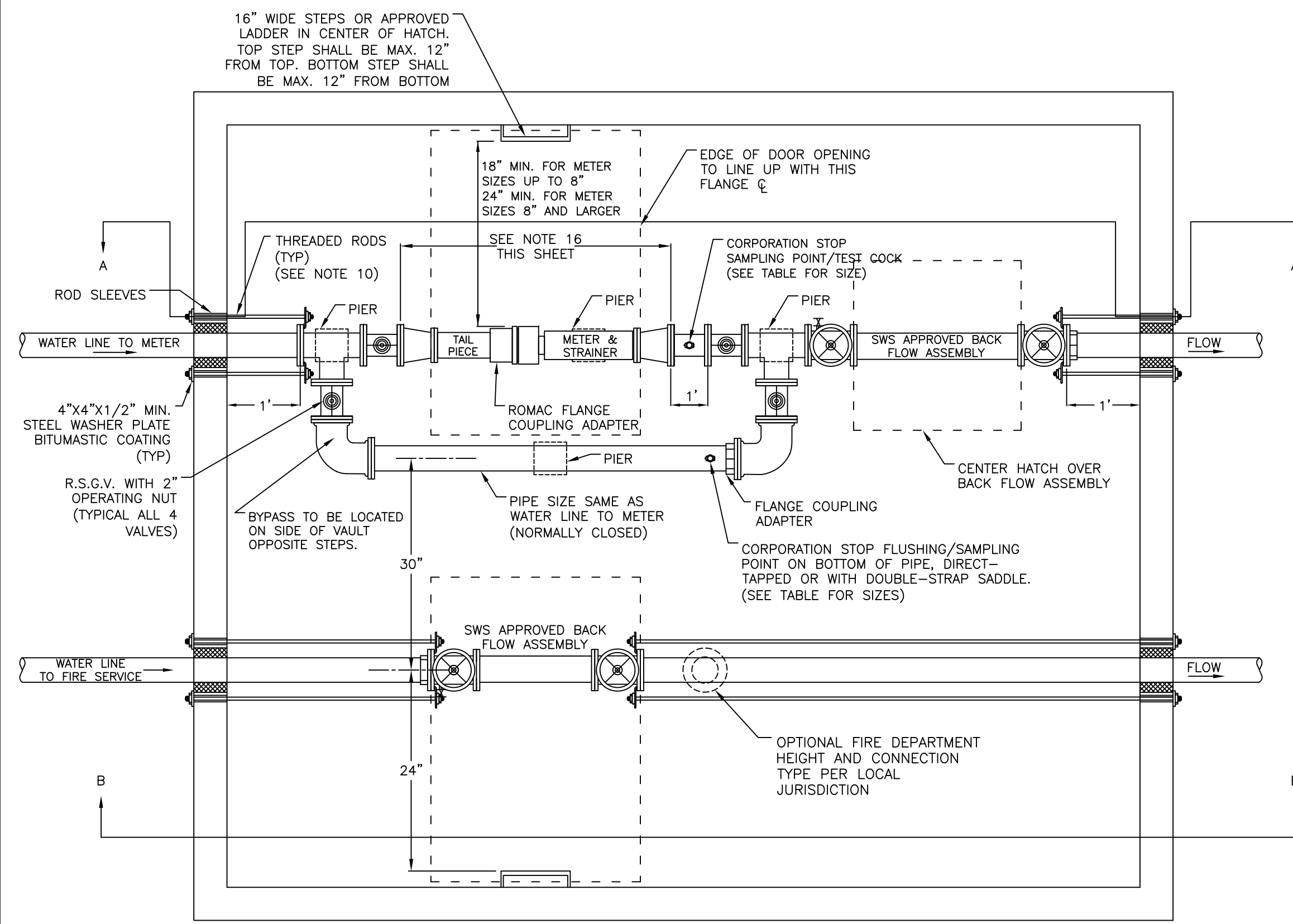

PLAN
NTS

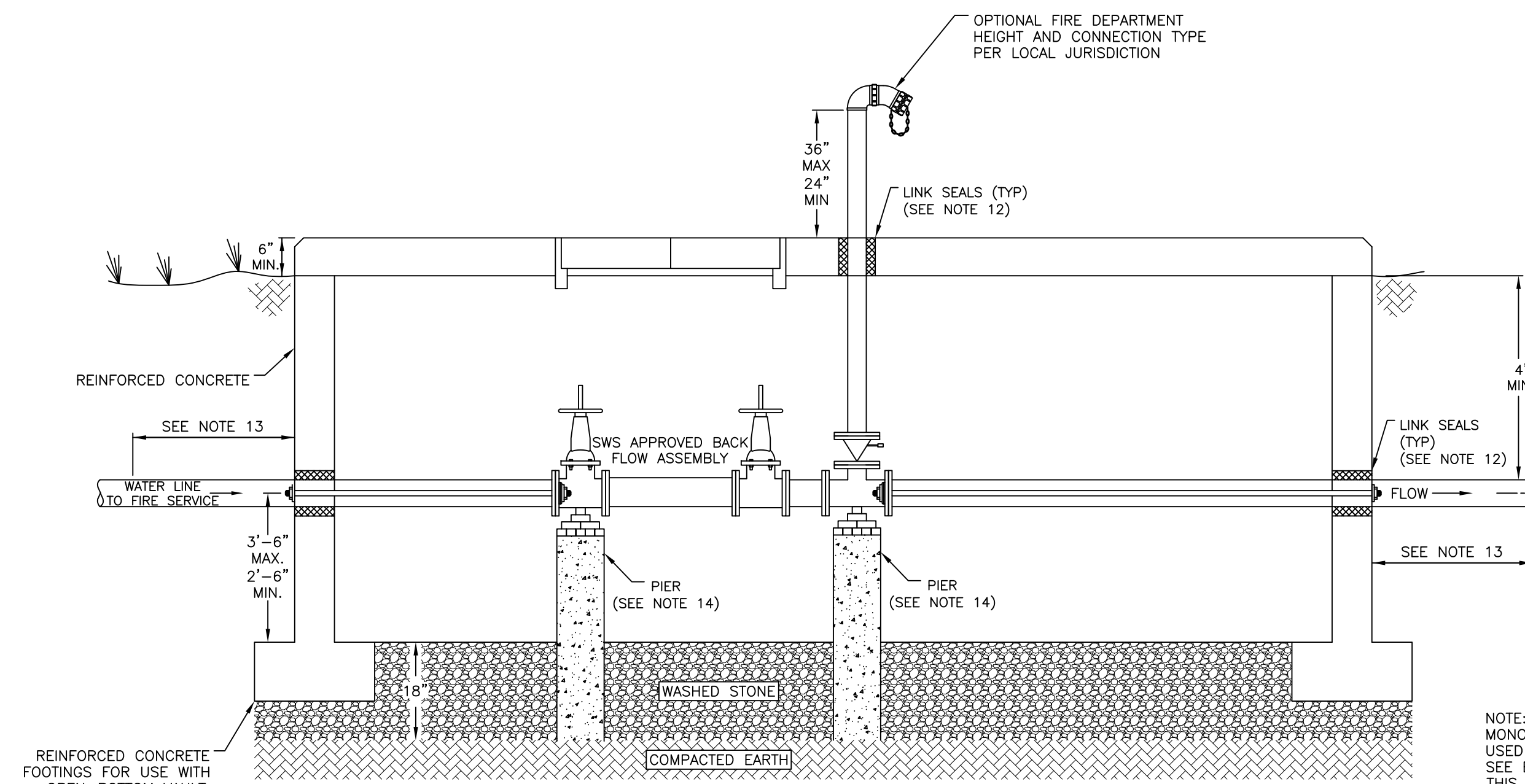

SECTION B-B
NTS

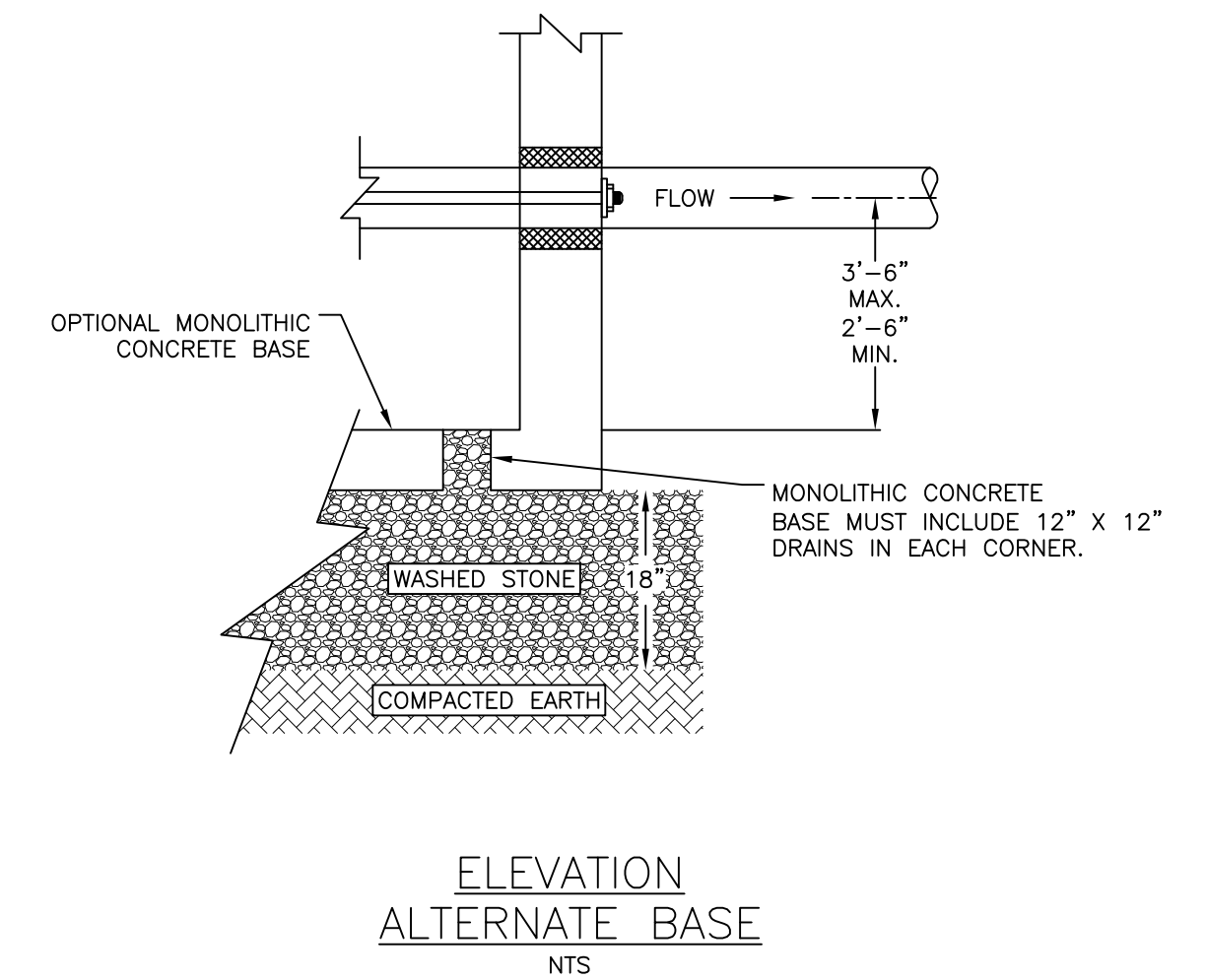

ELEVATION
ALTERNATE BASE
NTS

METER ASSEMBLY TYPES
TRU-FLO, HP-TURBINE, HP-PROTECTUS
NTS